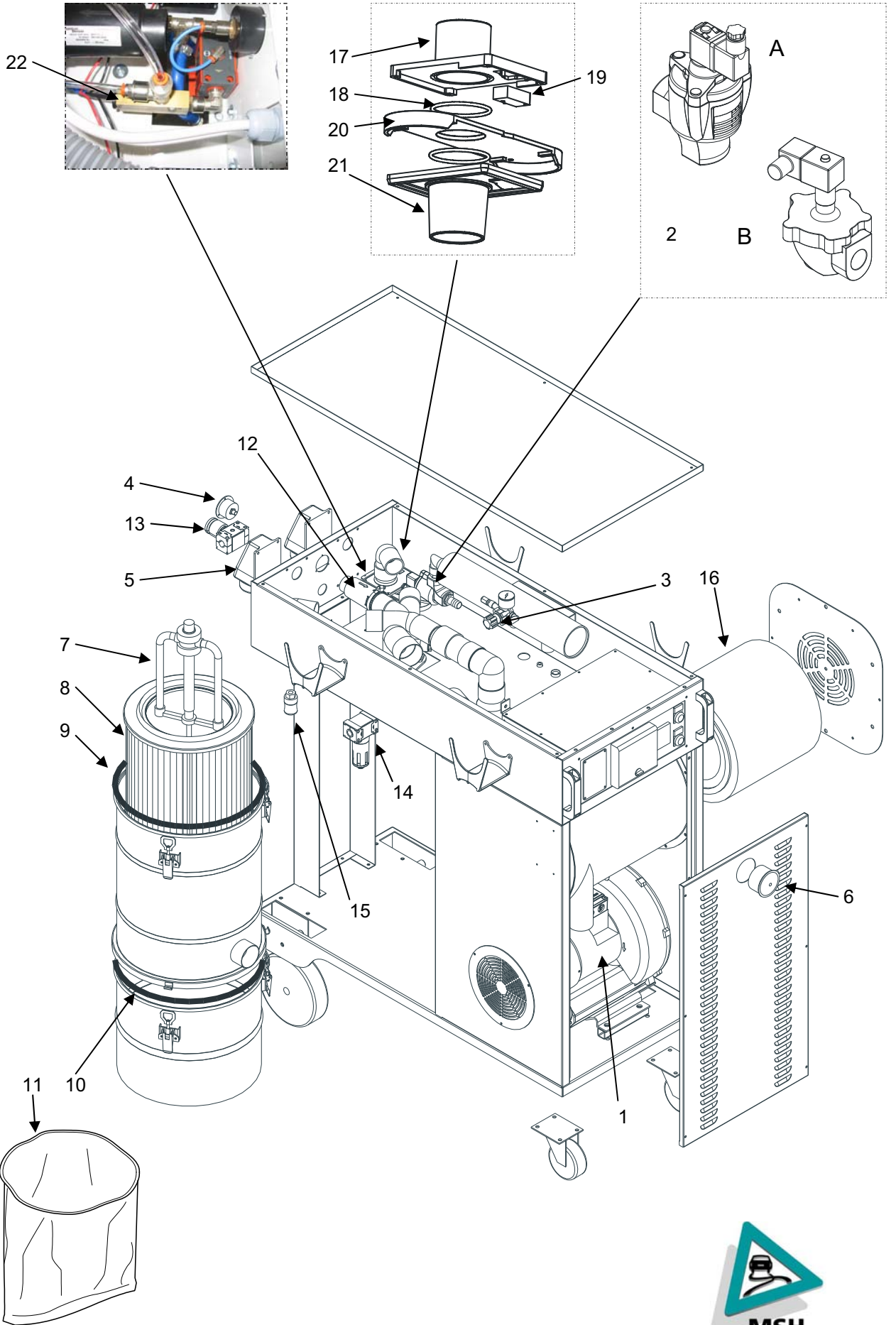

Table 8.1- A

POS.	DESCRIPTION	PART NO.
1	Side-channel blower	Ecologic Trolley 16: K15-41-S Ecologic Trolley 30: K30-1-S
2	Solenoid valve	A: 9029 B: 9018
3	Pressure regulator 1/4"	PCX-0001
4	Pressure gauge	35-59
5	Power socket	7606
6	Differential pressure gauge	8153
7	Dedusting device	K2-0080
8	Filter cartridge	K2-91-Alum
9	Top seal	7860-0106
10	Bottom seal	7867-0106
11	Dust collection bag	99988
12	Vacuum breaker valve (Ecologic Trolley 30 only)	V.L.P. 30
13	Pressure regulator 3/8"	K2-77
14	Compressed air filter 3/8"	6703
15	Safety quick cock 1/4"F	6304-1/4 green tag 6304-1/4-S blue tag
16	Hepa filter	HEPA
17	Microswitch carrier box	35-6-1008-ANT
18	O-ring	8111
19	Microswitch	9082
20	Gate valve	35-6-1003-ANT
21	Cover	35-6-1009-ANT
22	Pressure gauge	K2-78



Please see descriptions in Table 8.1 A